

SystemZone

Fluid Collection and Distribution Manifold

General information

SystemZone is a patented distribution manifold that collects heated or cooled fluid from one or more sources and distributes it to one or more zones. The unit illustrated here is designed for water circulation, but the unit is suitable for water, air or other fluids. Pumps are used to circulate the fluid and safety routes are always open. SystemZone is a cheap and simple alternative to custom designed, valve controlled zoning methods.

- SystemZone isolates and controls heating water collection and distribution circuits. Each circuit is independent of all others – no water flows if the circuit’s pump is not operating. This makes for simple design and fault-free installation.
- SystemZone stratifies hot and cold water, ensuring that zones draw from only the hottest water. This improves efficiency and speeds up system heat-up time.
- SystemZone has connection points for ancillary safety devices, safety valves and expansion tanks. It has an unobstructed internal baffle system and contains no moving parts for long-term trouble free use. SystemZone also eliminates the need for motorised valves, non-return valves and a system bypass.
- In a standard, simple configuration, one or two boilers may be connected to the SystemZone. SystemZone is ideal for efficiently connecting multiple types of heat generators including ground source heat, solid fuel stoves, solar heating, gas and oil boilers.
- SystemZone is particularly suited to systems where high velocity is required such as ‘Micro-bore’, one-pipe radiator systems and under-floor heating because it uses an individual pump for each zone. This means independent pump speeds may be selected to closely match a particular zone’s water velocity requirements.
- SystemZone is suitable for the largest commercial, industrial and district heating applications. These use custom made units scaled to the loads required. The SystemZone can also be used as a dosing pot for introducing chemicals to the system.
- SystemZone makes it simple to use multiple boilers because each boiler is automatically isolated from all the others without the need for valves. This allows specifiers of larger systems to easily reap the consequential benefits of reduced installation cost, lower running cost and improved reliability.

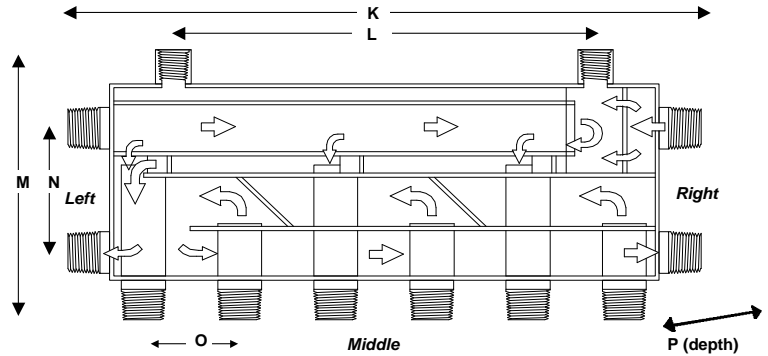
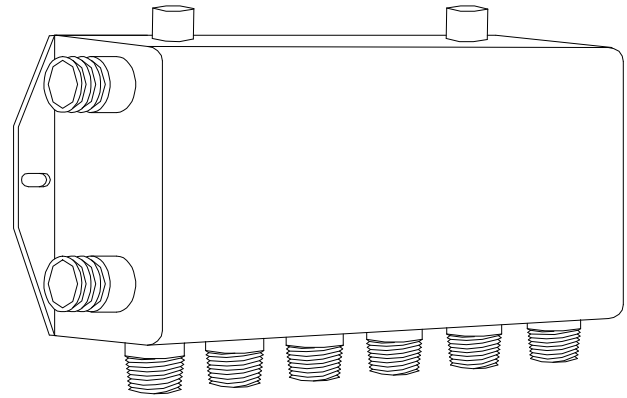

Product code explanation

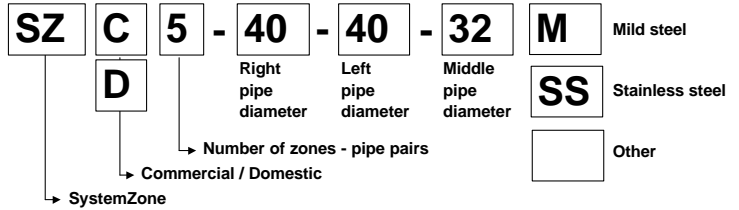

- Simple system layout
- Built in system bypass
- Superior system circulation
- Motorised valves not required
- Substantial labour and material savings
- Suitable for single or multi boiler applications
- Unobstructed cold feed, vent and expansion facility
- System pumps placed for optimum effectiveness
- Removes air from the system by design
- Extremely safe design

Technical Data

Description	Product code	Material	Pipe sizes (mm)				Dimensions (cm)						Maximum recommended heat capacity (Kw) per zone *		
			Left	Right	Middle	Top	K	L	M	N	O	P	Left	Right	Middle
4 Zone	SZD4-28-28-28 MS	Mild Steel	28	28	28	15	32.1	28.4	15.0	9.5	7.0	10.0	43	43	43
5 Zone	SZD5-28-28-28 MS	Mild Steel	28	28	28	15	46.1	42.5	15.0	9.5	7.0	10.0	43	43	43
6 Zone	SZD6-28-28-28 MS	Mild Steel	28	28	28	15	60.1	56.4	15.0	9.5	7.0	10.0	43	43	43
4 Zone	SZC4-32-32-28 MS	Mild Steel	32	32	28	15	32.1	28.4	15.0	9.5	7.0	10.0	56	56	43
5 Zone	SZC5-32-32-28 MS	Mild Steel	32	32	28	15	46.1	42.5	15.0	9.5	7.0	10.0	56	56	43
6 Zone	SZC6-32-32-28 MS	Mild Steel	32	32	28	15	60.1	56.4	15.0	9.5	7.0	10.0	56	56	43
4 Zone	SZC4-40-40-32 MS	Mild Steel	40	40	32	15	42.0	39.8	18.0	11.7	10.0	12.5	87	87	56
5 Zone	SZC5-40-40-32 MS	Mild Steel	40	40	32	15	62.0	58.6	18.1	11.7	10.0	12.5	87	87	56
6 Zone	SZC6-40-40-32 MS	Mild Steel	40	40	32	15	82.0	78.6	18.1	11.7	10.0	12.5	87	87	56
4 Zone	SZC4-50-50-32 MS	Mild Steel	50	50	32	22	52.2	50.0	20.0	12.5	12.5	15.0	137	137	56
5 Zone	SZC5-50-50-32 MS	Mild Steel	50	50	32	22	77.2	74.2	20.0	12.5	12.5	15.0	137	137	56
6 Zone	SZC6-50-50-32 MS	Mild Steel	50	50	32	22	103.7	100.7	20.0	12.5	12.5	15.0	137	137	56
4 Zone	SZC4-50-50-40 MS	Mild Steel	50	50	40	22	52.2	50.0	20.0	12.5	12.5	15.0	137	137	87
5 Zone	SZC5-50-50-40 MS	Mild Steel	50	50	40	22	77.2	74.2	20.0	12.5	12.5	15.0	137	137	87
6 Zone	SZC6-50-50-40 MS	Mild Steel	50	50	40	22	103.7	100.7	20.0	12.5	12.5	15.0	137	137	87

* Water at velocity 1.5m/sec, 11 degC design temperature differential