



KRIIB

Hot Water On Demand

Installation Manual

Retrofit System

V 11G

systemlink
Technologies

CAUTION! Under no circumstances, should high and low voltage circuits be conducted through contacts on the same relay, as this would not comply with minimum clearance requirements specified by international wiring regulations. If a control is required on a circuit of different voltage than the primary circuit, the auxiliary control relay should be used.

CAUTION! This specification relates to the KRIB family of products. It specifies operating conditions and installation requirements for the KRIB assuring correct and safe operation. The KRIB should only be installed by suitably qualified professional. Systemlink accepts no responsibility for installation and use of KRIB equipment unless these requirements are strictly adhered to. Systemlink reserves the right to amend this specification and the KRIB product configuration as it sees fit.

CAUTION! To avoid potential problems of legionella bacterial growth within a hot water cylinder it is advisable to keep the stored water temperature at 60°C, or, if water is stored at a lower temperature than this, that the whole cylinder is heated to 60°C once per week (This is the case with many heat pumps. Consult heat pump manual for details).

Water Quality

CAUTION! If the KRIB is installed in an area where limescale is present in the water then the water must be treated with a water softener. Otherwise there is the possibility that limescale could block the heat exchanger. Heat Exchangers damaged by scaling are not covered by warranty. If the water exceeds the values below a water softener should be installed:

Description	pH	Total Dissolved Solids (TDS)	Total Hardness	Chlorides	Magnesium	Calcium	Sodium	Iron
Maximum Recommended Levels	6.5-9.0	600 mg/litre	150 mg/litre	300 mg/litre	10 mg/litre	20 mg/litre	150 mg/litre	1 mg/litre

Introduction

Systemlink's patented KRIB system fills the cylinder from the top down with hot water, so as soon as the system switches on, hot water is available immediately and thanks to an intelligent control system, allows the user to heat precisely the quantity of water they require when they require it, thereby saving and reducing energy consumption.

In addition, the KRIB gives the user control of their heating system from anywhere with the KRIB App.

Wi-fi is **not** required to operate the KRIB system. Internet is only required if the user wants control of the heating system through the smartphone App.

The KRIB system comprises of 3 main components, the Touchscreen, Gateway and Heat Exchange Module.



All installation work should be carried out by a suitably qualified professional.

KRIB Mechanical System Set-Up

1. Connect boiler flow/return pipework which would normally be connected to the coil of the domestic hot water cylinder to the Boiler Flow/Return connections of the KRIB instead.
2. Make connections using Tee connectors from the KRIB to the domestic hot water cylinder cold-in and hot-out, as shown in the installation diagrams.
3. Install the supplied Multi-Flange inserts as shown on pages 12 & 13. Screw a 311 or 312 fitting into the top of the hot water cylinder depending on whether it is a male or female connection. Place the Multi-Flange Insert into a standard Compression Tee. A pipe stub inserted between the Tee and the 311 fitting, can be adjusted to length to vary the insertion distance of the Flange into the cylinder body. Usually a stub length of approx. 80mm is suitable. When a pipe is inserted into the top side of the Tee, push it fully home against the Multi-Flange Insert as this will hold it securely in place.
4. Note the 1" BSP Flow Sensor should be installed on the cold-in of the cylinder as shown in the installation diagrams.
5. Check the pump setting. To do this push briefly on the button on the pump face. LED's 1(red), 3(yellow) & 5(yellow) should light up. If not, the pump setting is adjusted as follows: Push and hold the button for between 2 & 10 seconds. Pump is now in selection mode. Cycle through the various programs by pressing the button repeatedly. When it arrives on the correct setting (LED's 1,3,5 as above) do not touch anything for 10 seconds at which point the pump saves the setting.

KRIB Electrical Wiring Set-Up

1. CAUTION! The KRIB should only be installed by a suitably qualified professional.
2. Before installation, the mains electricity supply should be isolated. Test, confirm and make sure it is secured in the off position for the duration of the installation.
3. Choose the appropriate electrical wiring diagram to correspond with the chosen mechanical set-up as shown on the following pages.
4. Wire the boiler, all zone thermostats and pumps/motorised valves to the KRIB wiring panels as shown in the chosen wiring diagram. The flow sensor and the Touchscreen have been pre-wired but may be extended if necessary.
5. Avoid running low voltage wires in parallel with 230V wires.

Installation Diagrams

A Standard S-Plan plus system typically looks like the diagram below.

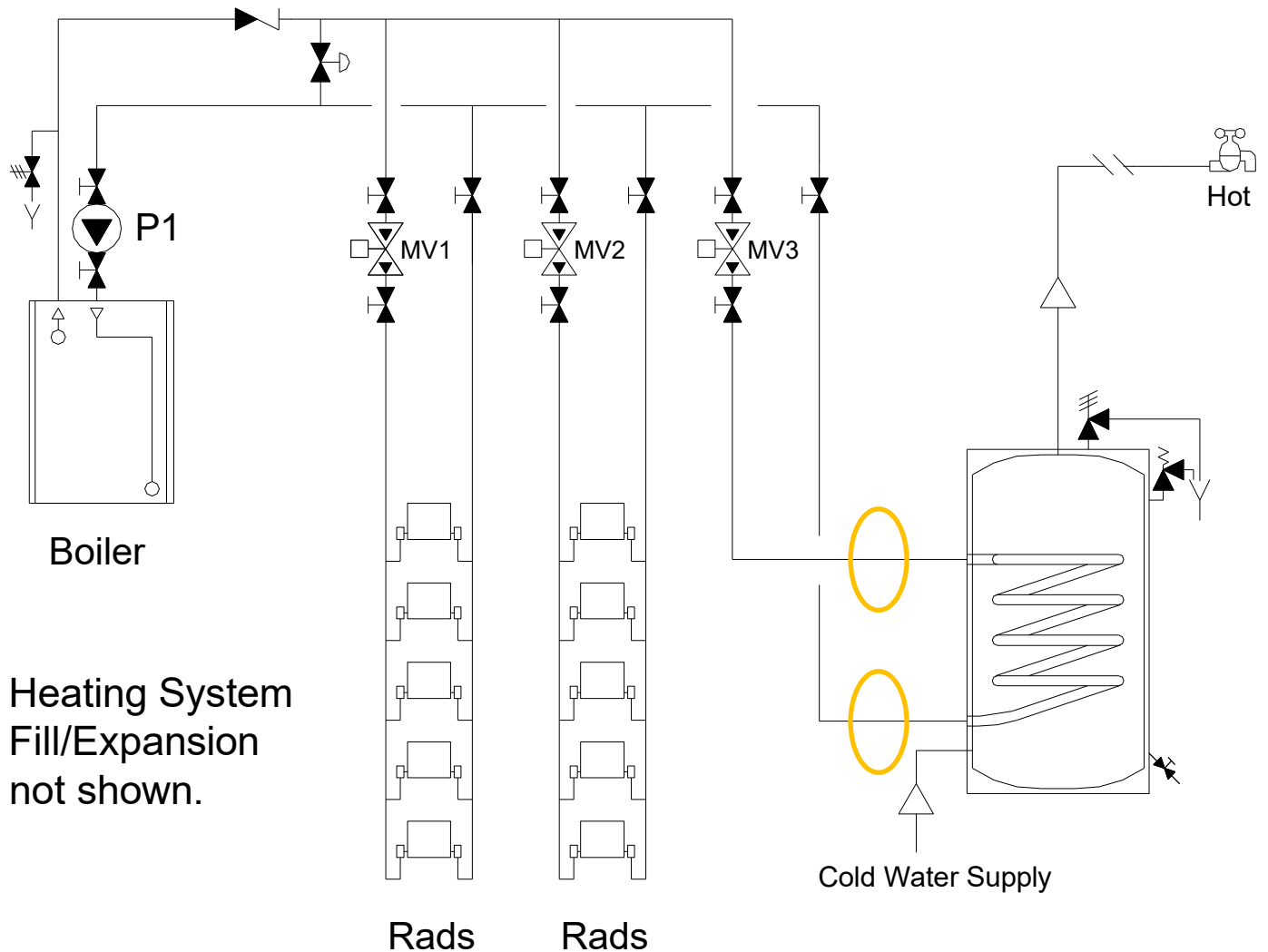

Schematic 1. Typical 3-Zone System with Motorised Valves.

The connections from the boiler to the hot water cylinder, circled in yellow above, should be disconnected from the cylinder and connected to the KRIB instead, as shown below.

For Open vented cylinder systems mount the KRIB heat exchanger at a level that is below the top of the cylinder.

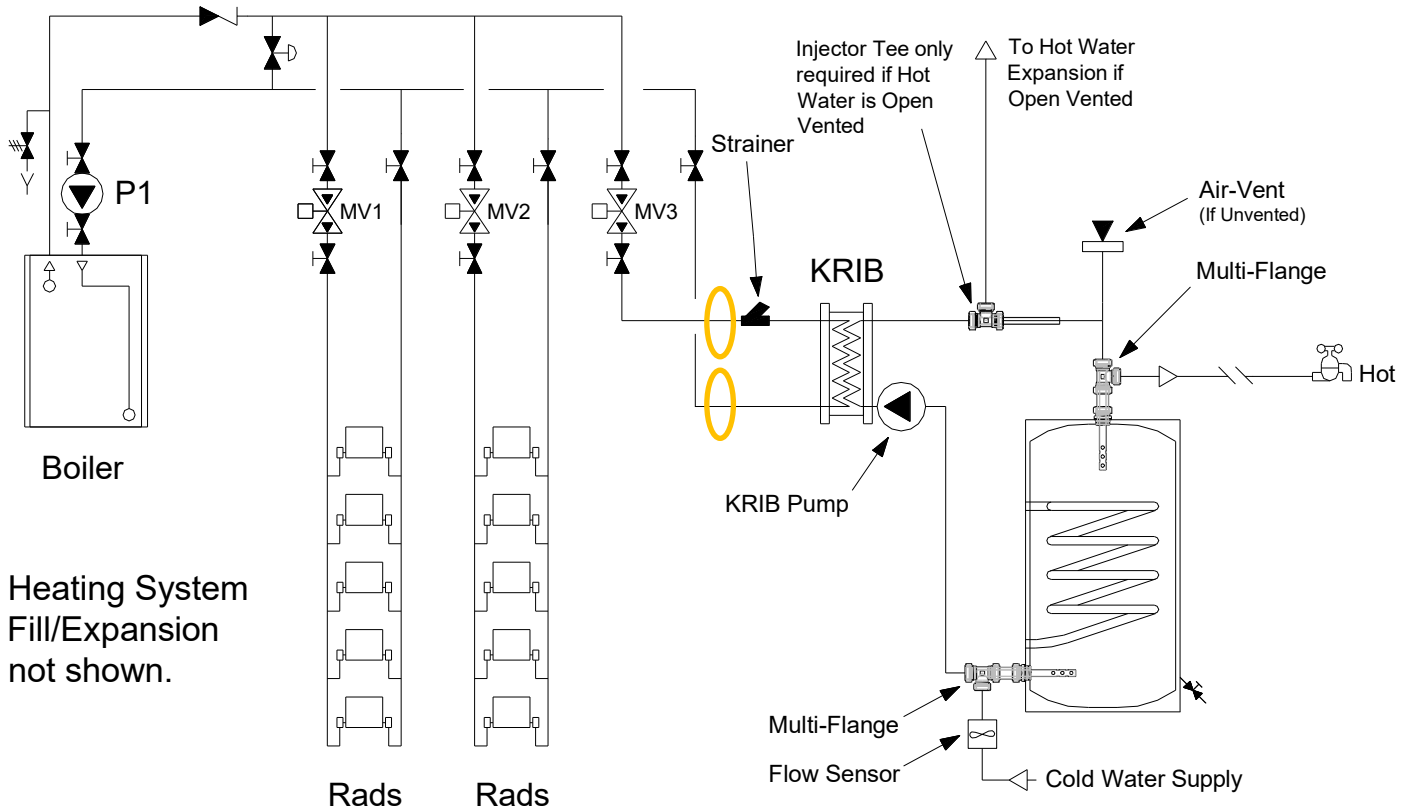

Schematic 2. Typical 3-Zone System with Motorised Valves and Domestic Hot Water connected through a KRIB (Close-up Below).

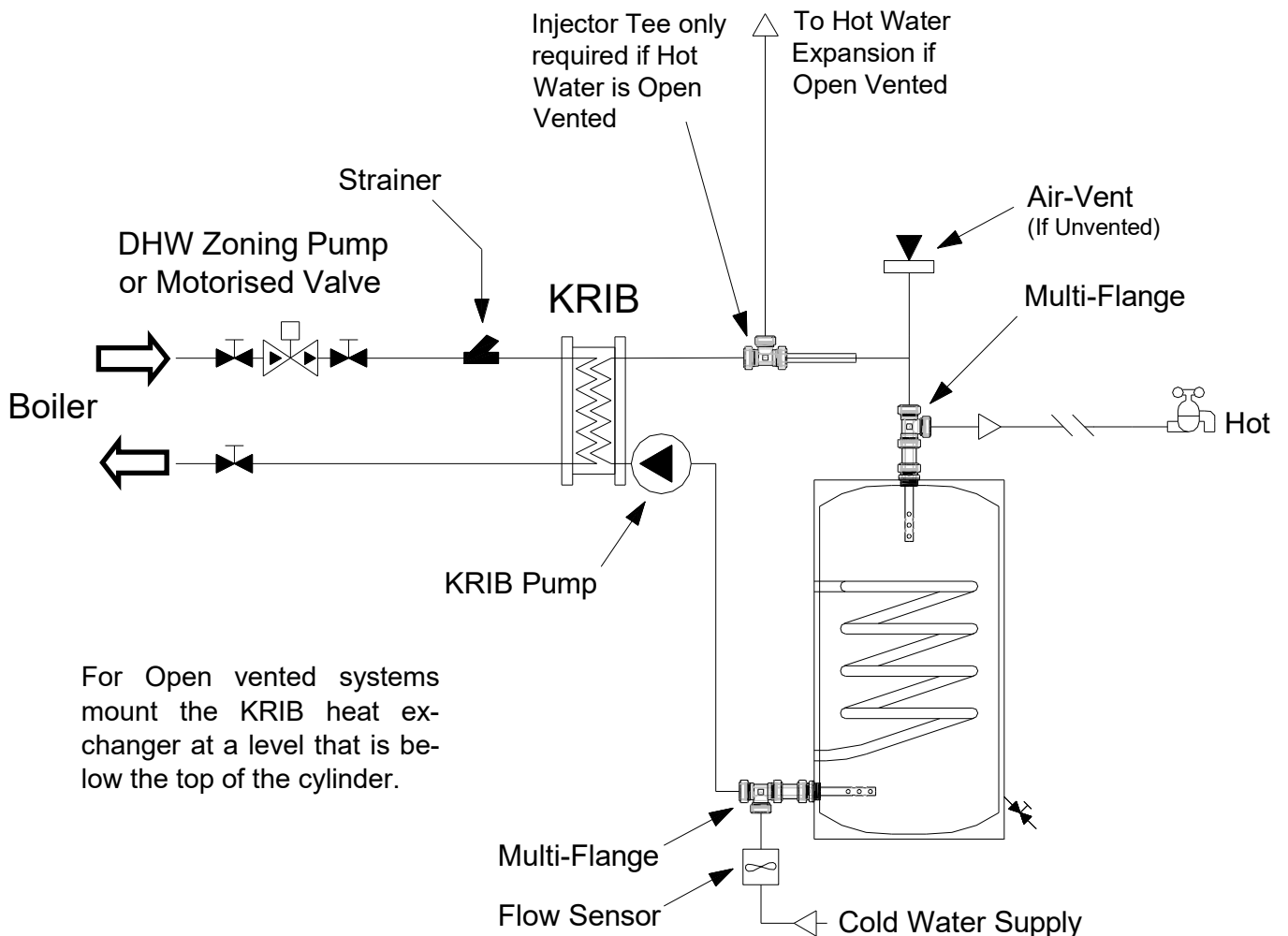

KRIB connected to a system zoned with pumps

Disconnect hot water coil and reconnect through the KRIB as shown with the yellow markings below.

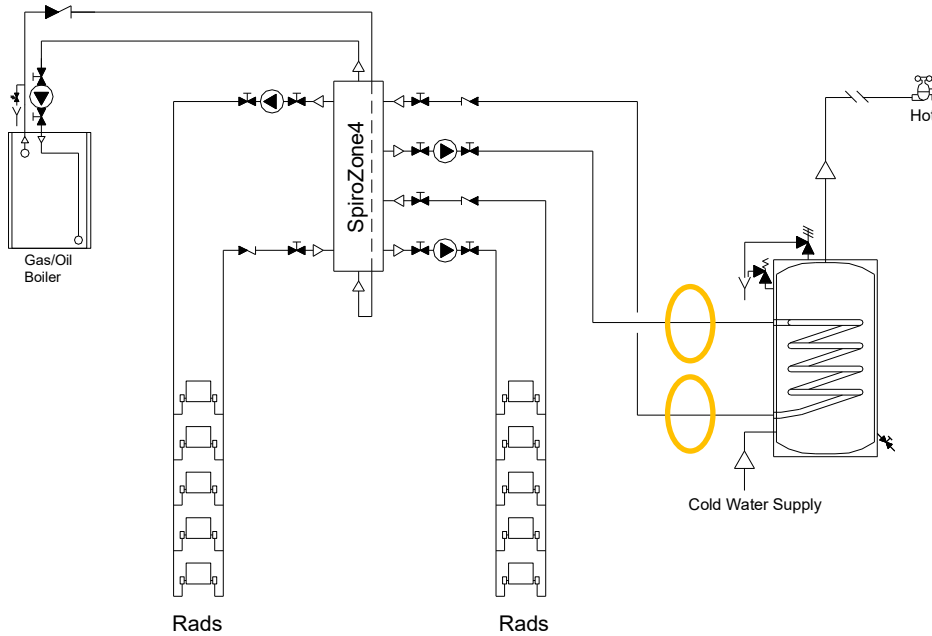

Schematic 3. Typical 3-Zone System zoned with pumped manifold

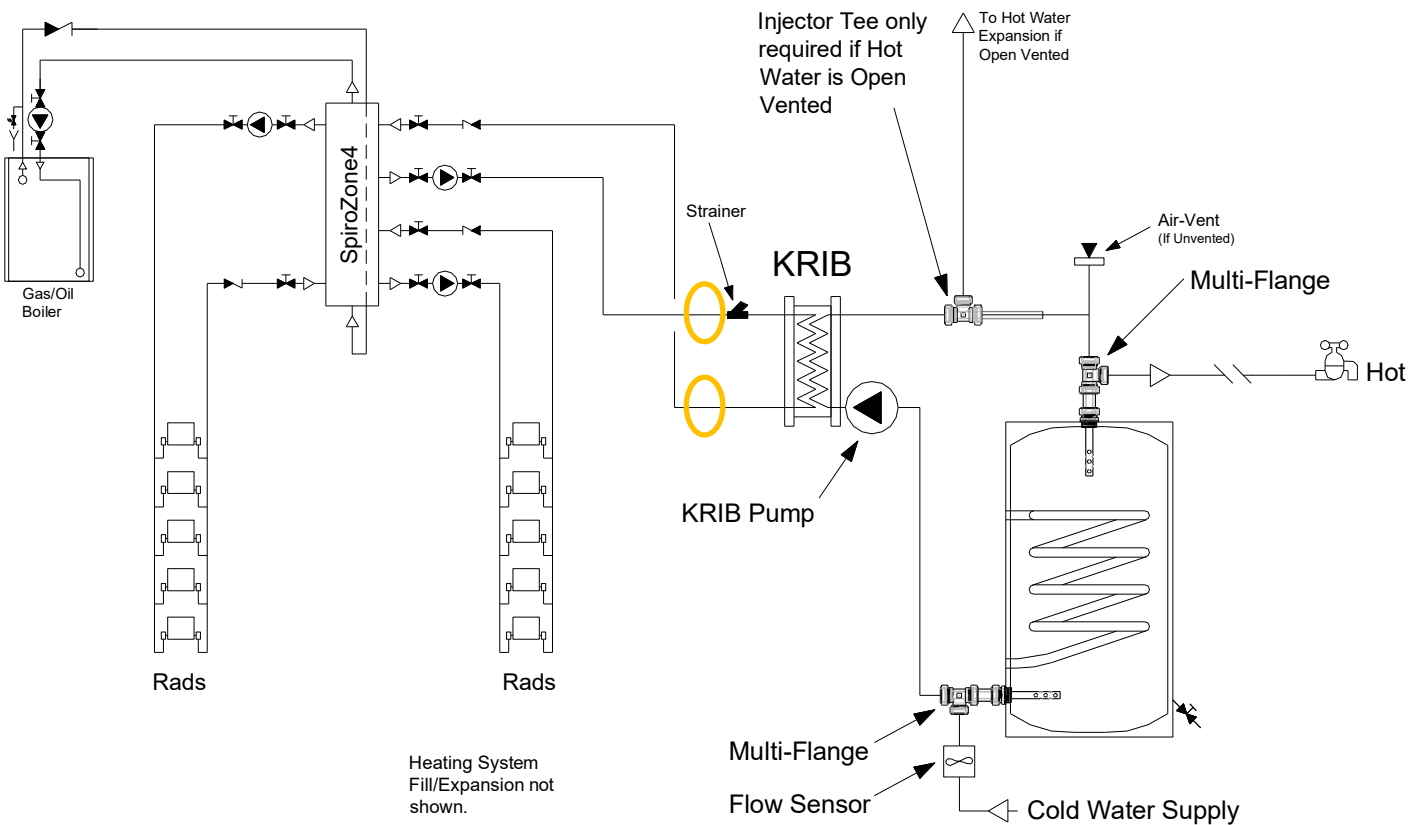

Schematic 4. Typical 3-Zone System zoned with pumped manifold and Domestic Hot Water connected through a KRIB

A Multi-Flange connection should be used on both cold-in and hot-out of cylinder. This allows a second neutralised connection to be taken off of each.

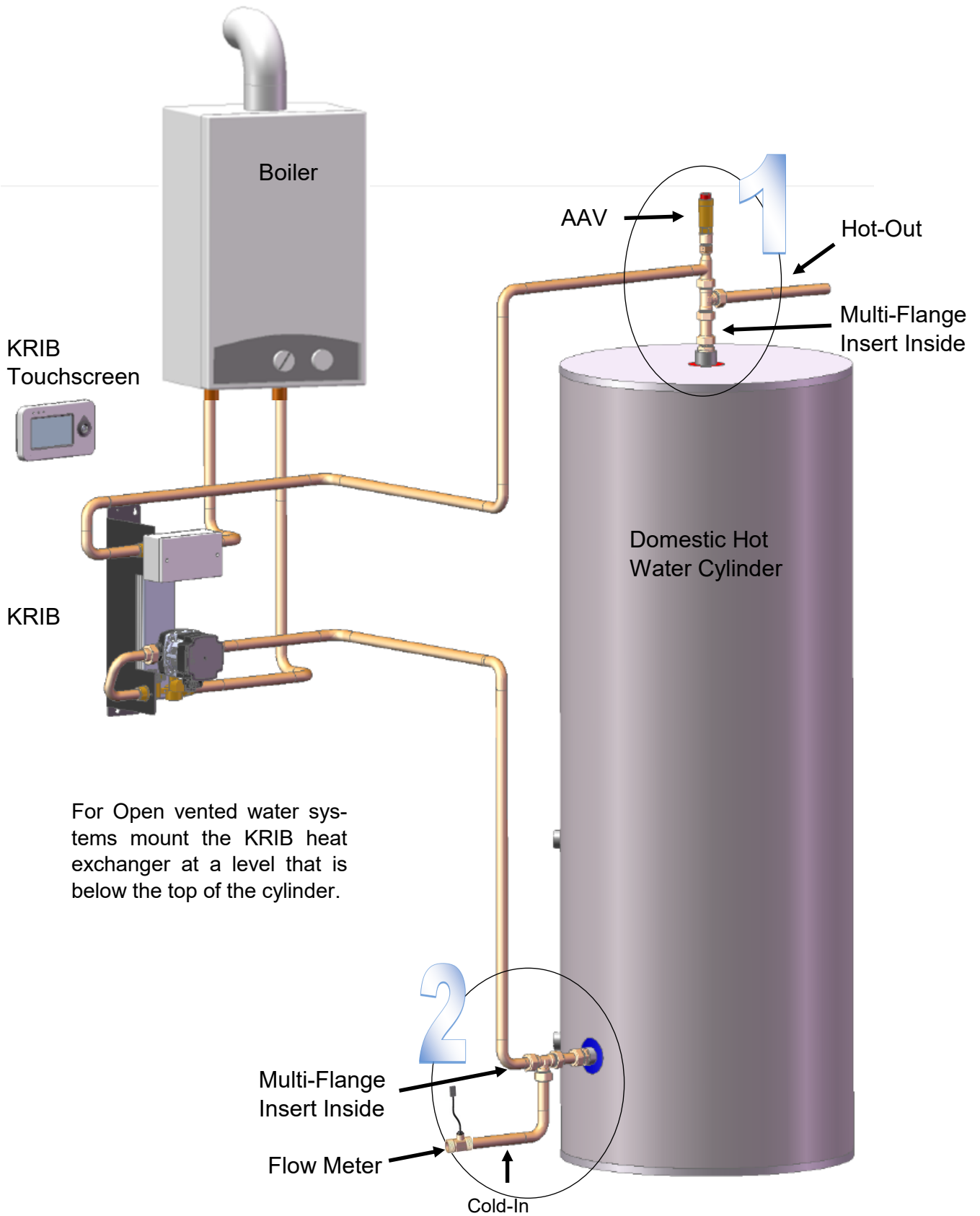

1

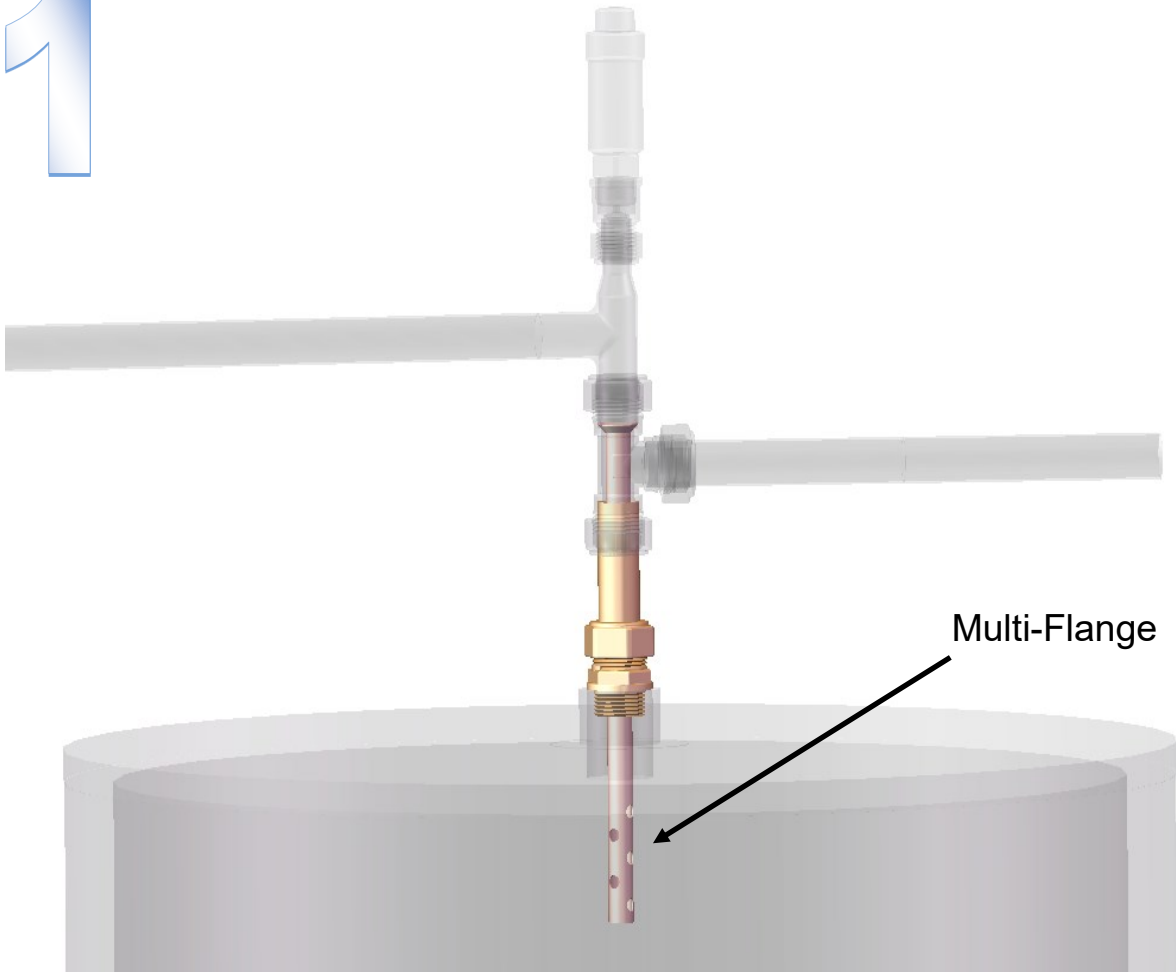

2

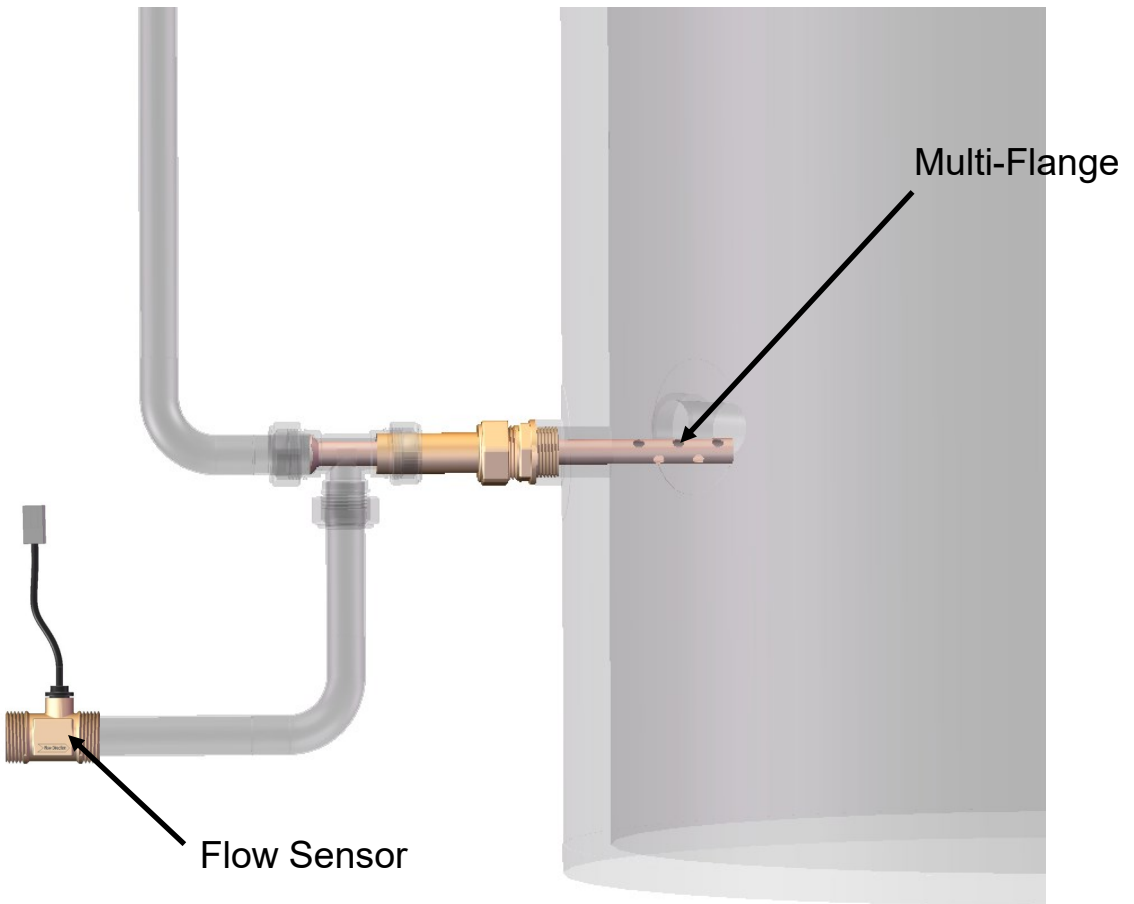

DHW Out to
Top of Cylinder

Boiler Flow

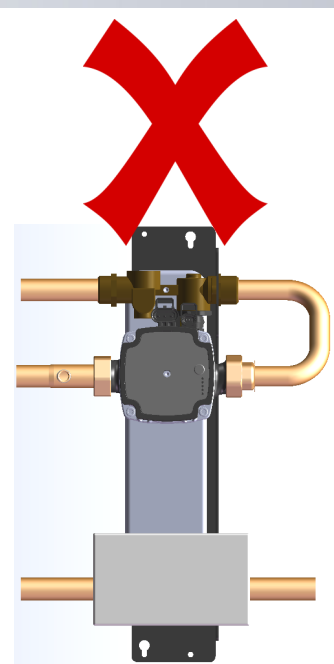
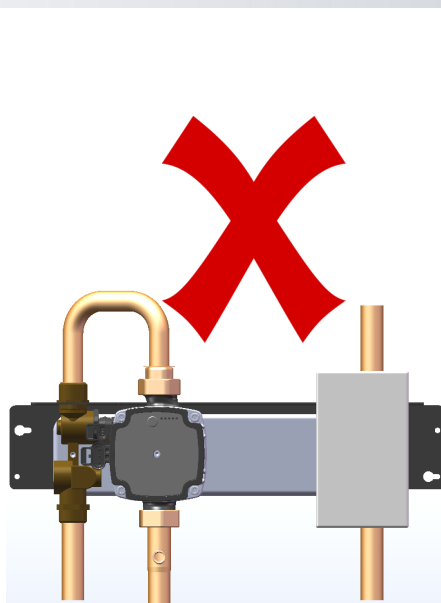
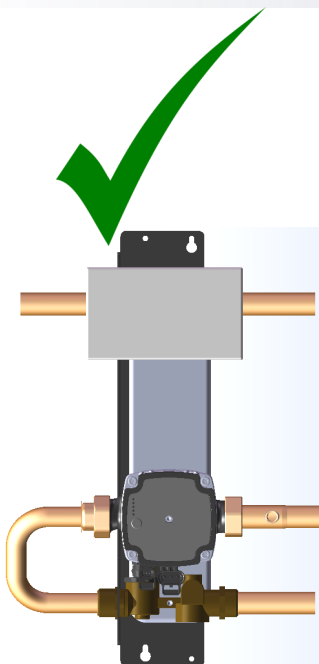
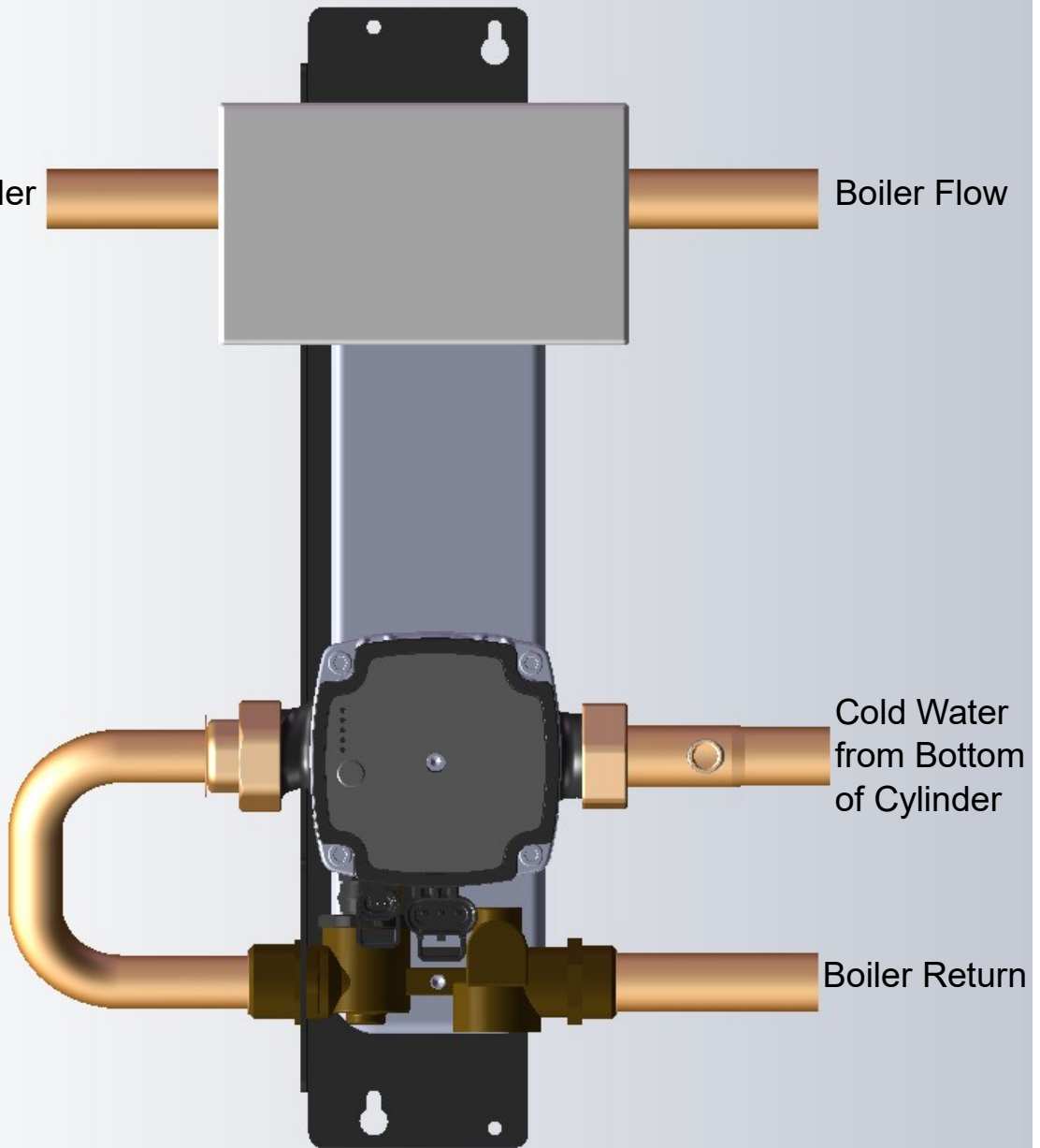

Mounting the Touchscreen

Choose a suitable location to mount the Touchscreen. Bear in mind that it reads and controls the temperature of the room in which it is mounted.

It should be between 1.2 and 1.5 metres from the floor and not exposed to heat sources (such as radiators or direct sunlight) or draughts (from open windows or doors).

Unclip the front bezel around the edges (starting at the left side) and remove to expose the 4 assembly screws located as circled in yellow below.

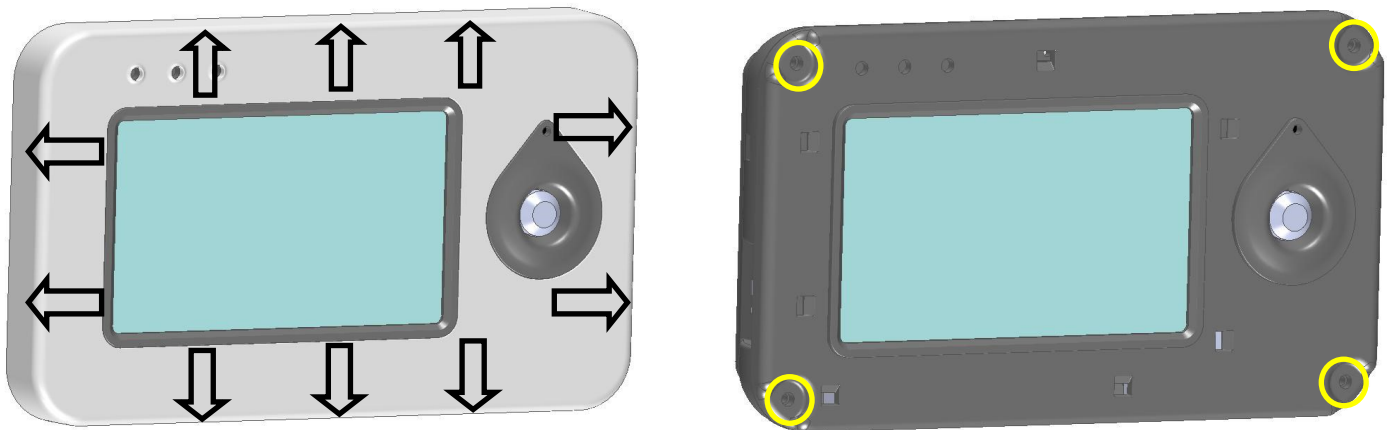

Remove these four screws and carefully remove the front of the Touchscreen, taking care not to damage the temperature sensor or connecting ribbon cable. Unplug the connecting ribbon cable to ease access if required.

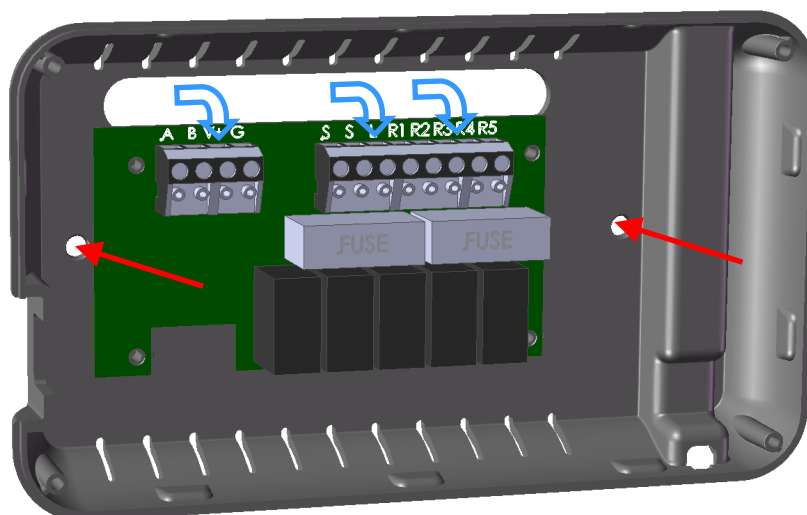

Mount the backplate directly to a wall or to a standard 2-gang electrical Pattress Box using the holes highlighted by the red arrows above.

Route electrical wires through the slot and into the connector blocks as highlighted by the blue arrows above.

Touchscreen PCB Connections

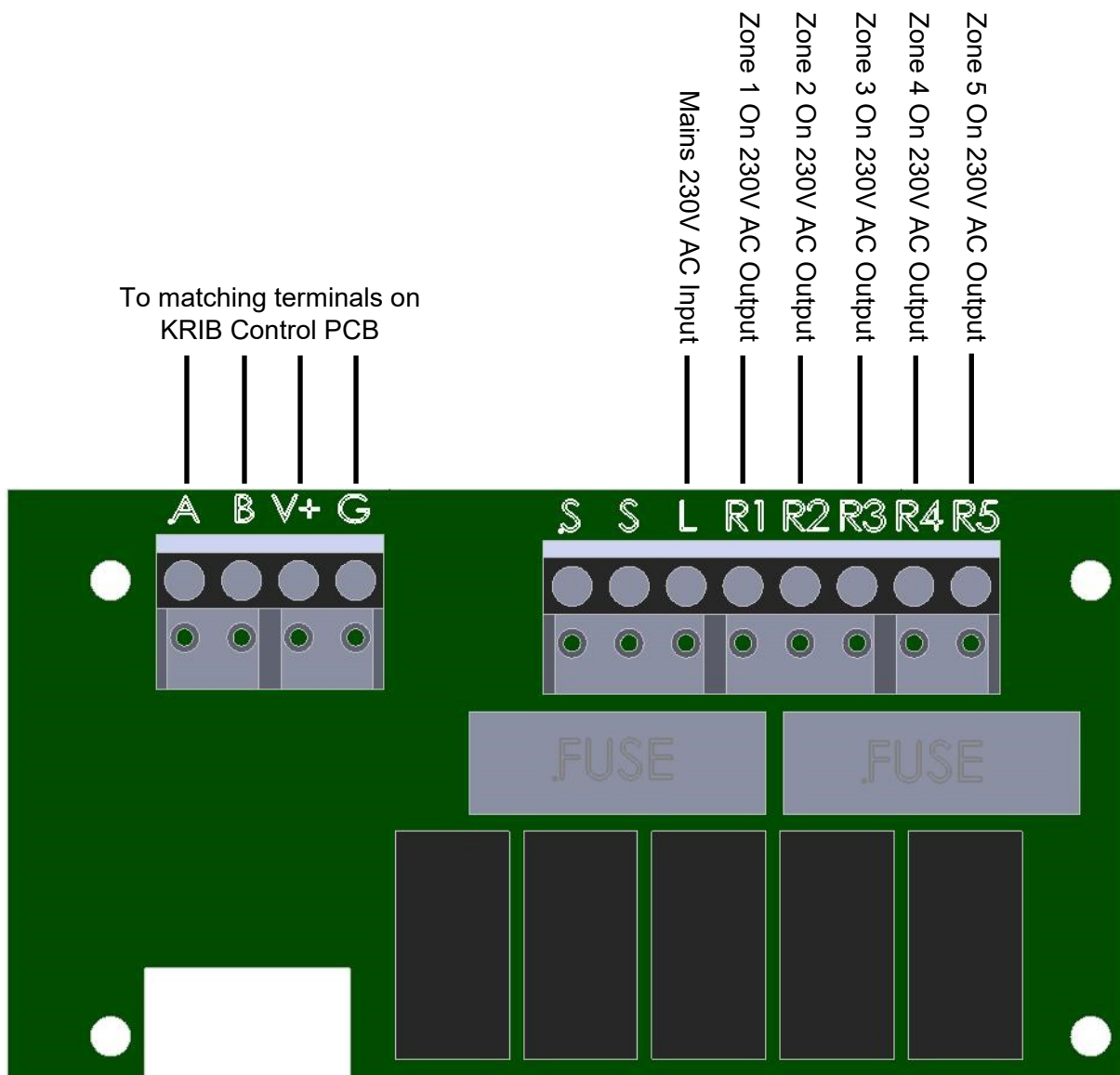
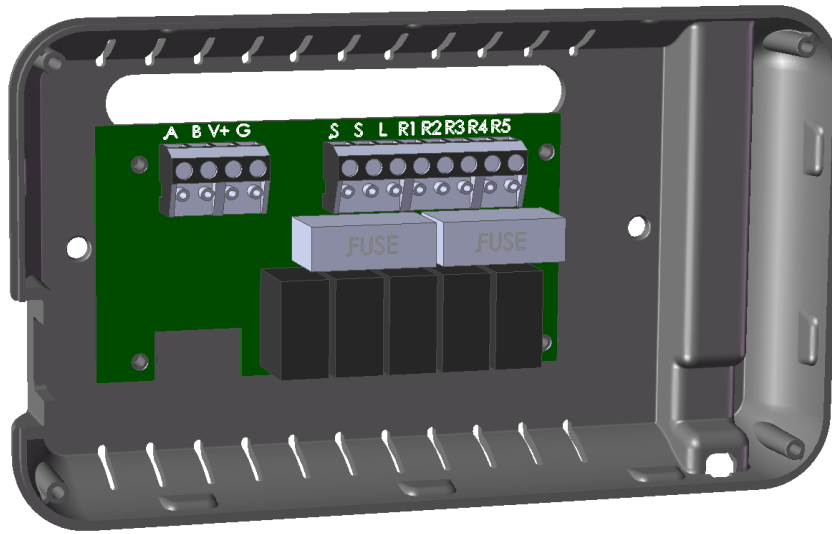

KRIB 230V Wiring Box Connections

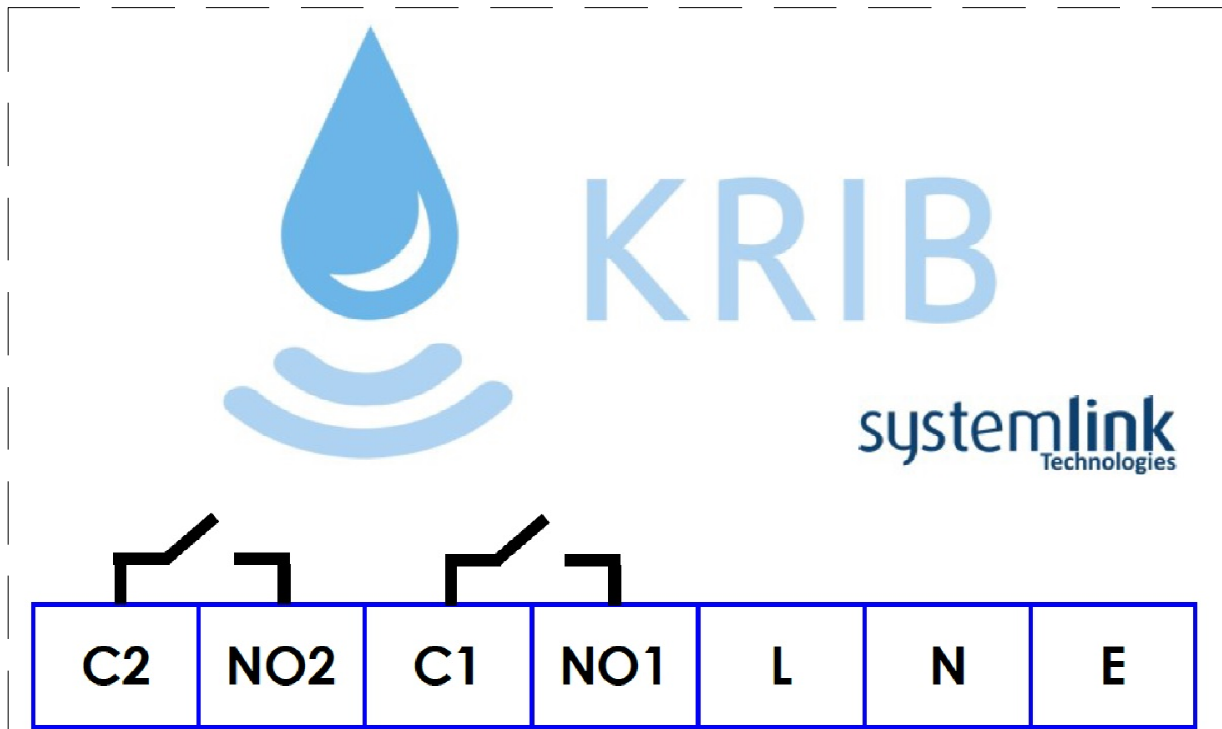

DHW Pump/Valve Control Relay Not in Use

230V AC Mains Supply Input

230V AC Wiring Connections for an KRIB system showing a boiler and 6 zones controlled by thermostats and a pump for each zone (5 heating zones and 1 Domestic Hot Water KRIB zone). If a pump is used on each zone a SystemLex is required for Boiler switching. SystemLex wiring on this page. KRIB DHW Zone wiring on next page. Boiler switched by SystemLex Control Relay.

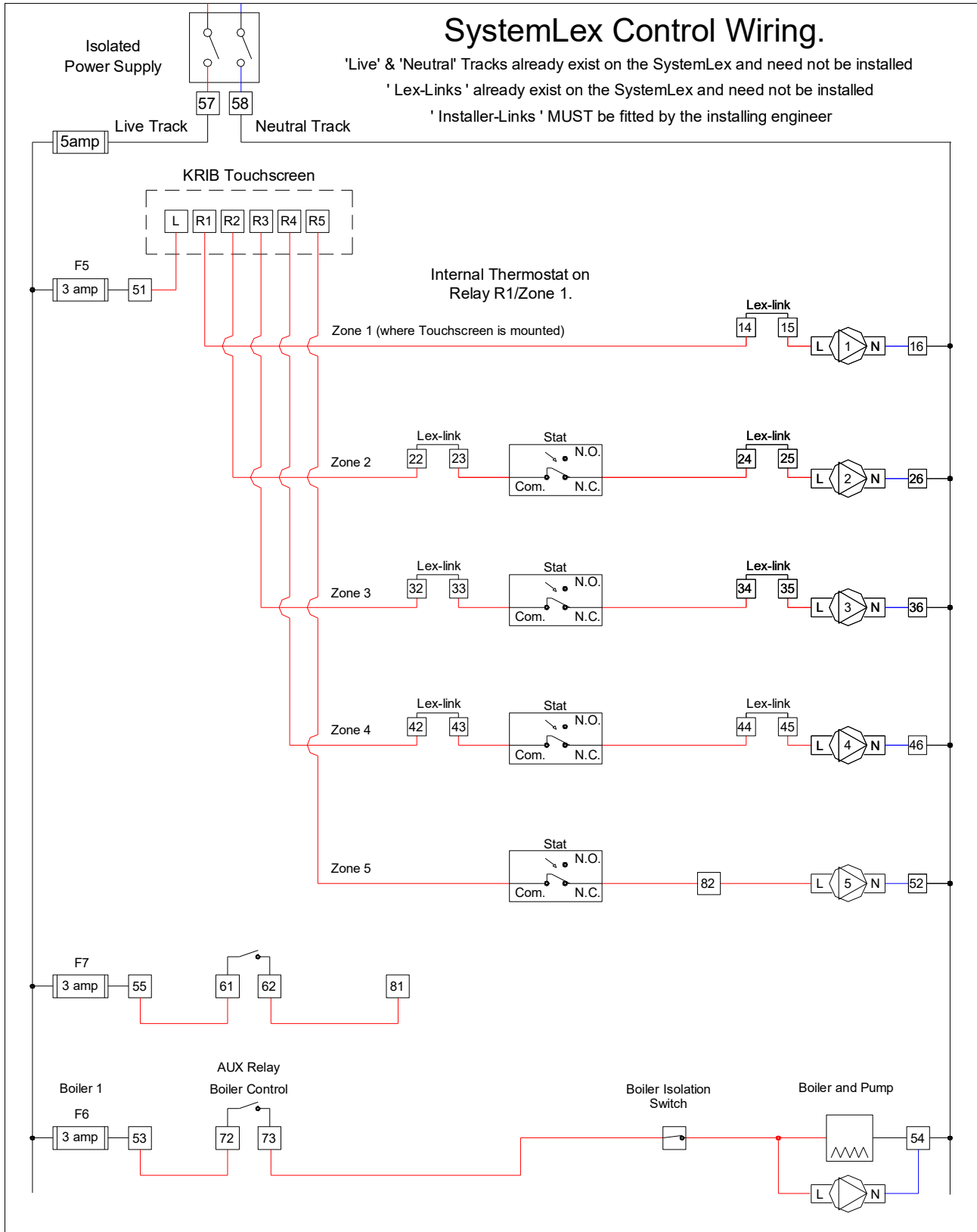

Schematic 5. Electrical Wiring for KRIB system zoned with pumps (option 1)

230V AC Wiring Connections for wiring of Boiler and Domestic Hot Water Pump to KRIB.

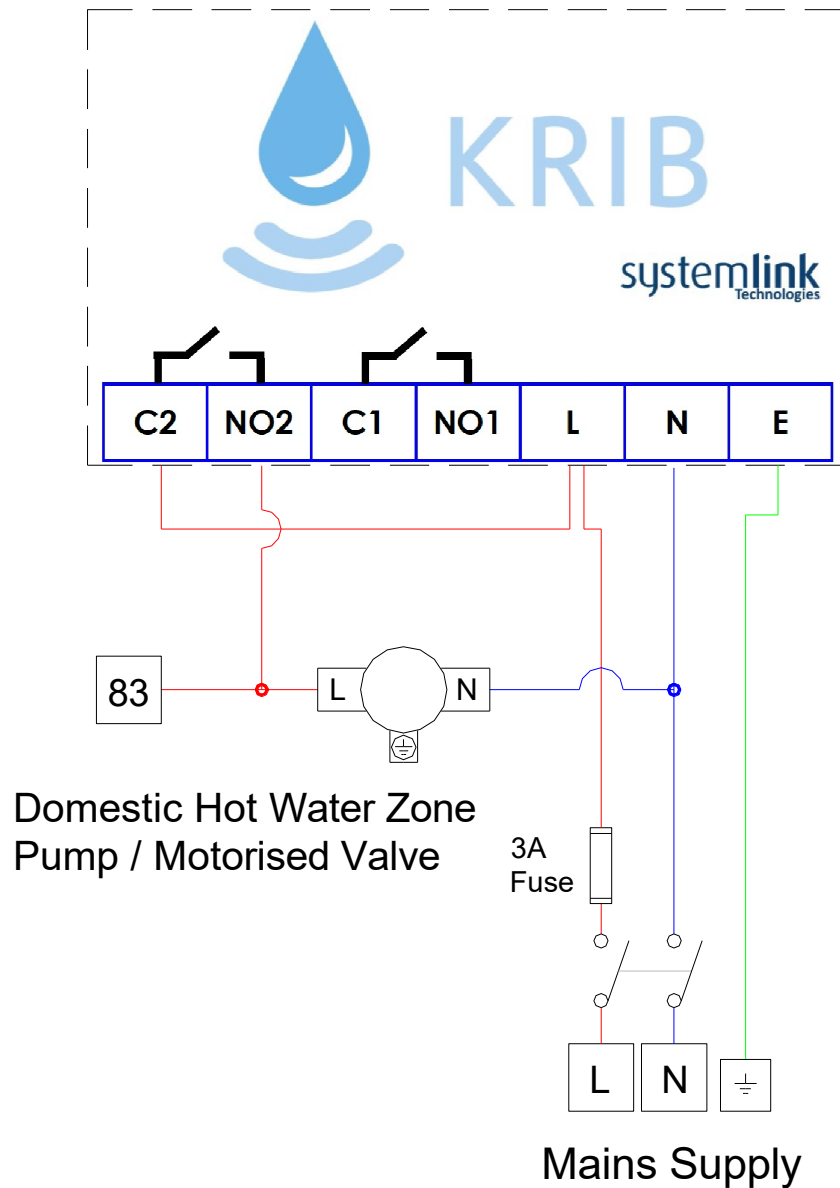

Schematic 6. Wiring for Boiler and Domestic Hot Water Pump

CAUTION! Under no circumstances, should high and low voltage circuits be conducted through contacts on the same relay, as this would not comply with minimum clearance requirements specified by international wiring regulations. If control is required on circuits of different voltage a separate control relay should be used.

230V AC Wiring Connections for an KRIB system showing a boiler and 6 zones controlled by thermostats and a motorised valve for each zone (5 heating zones and 1 Domestic Hot Water KRIB zone). Boiler switched by motorised valves auxiliary contacts.

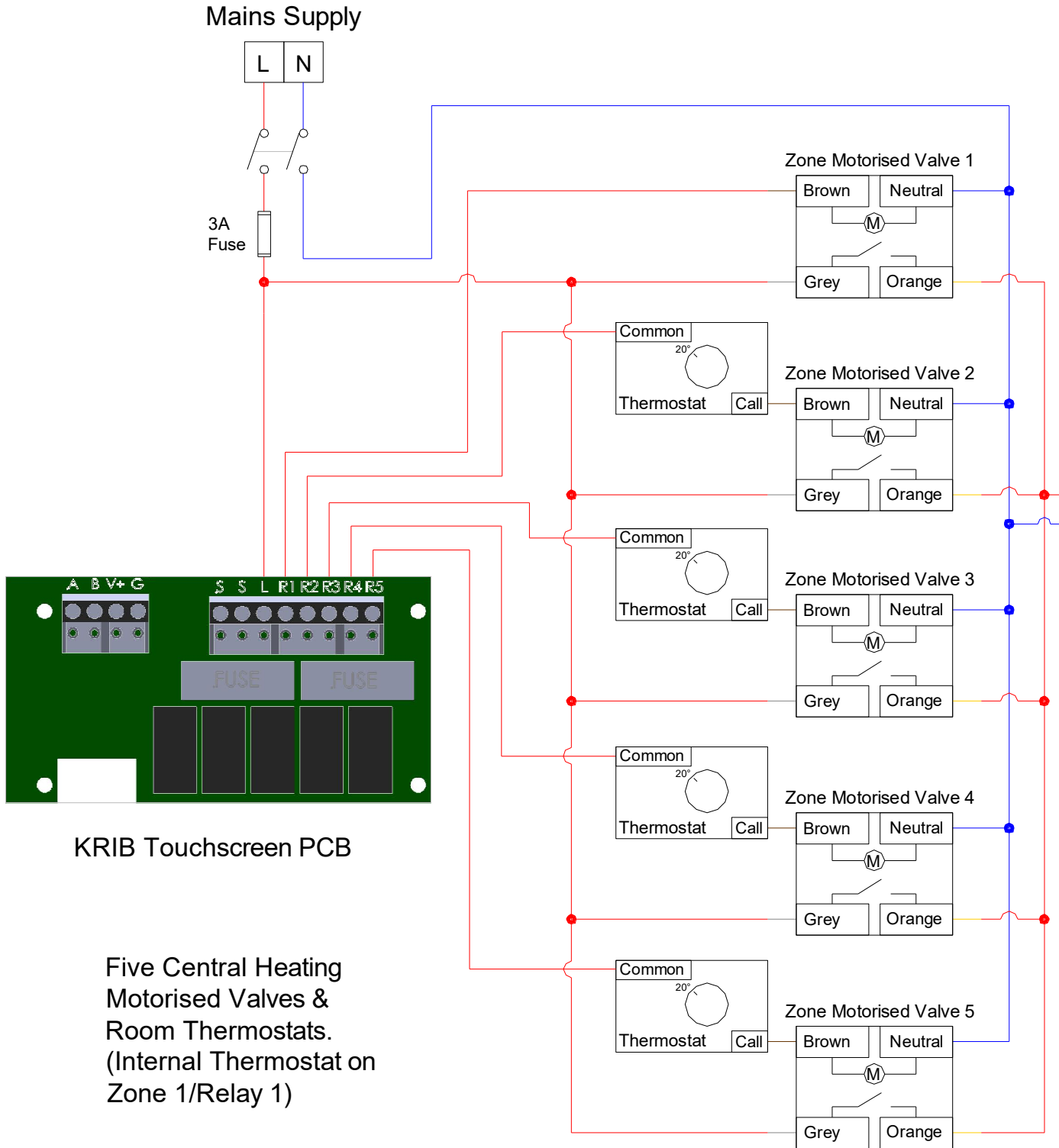

KRIB Touchscreen PCB

Five Central Heating Motorised Valves & Room Thermostats. (Internal Thermostat on Zone 1/Relay 1)

Schematic 7a. Electrical Wiring for KRIB system zoned with motorised valves (option 2)

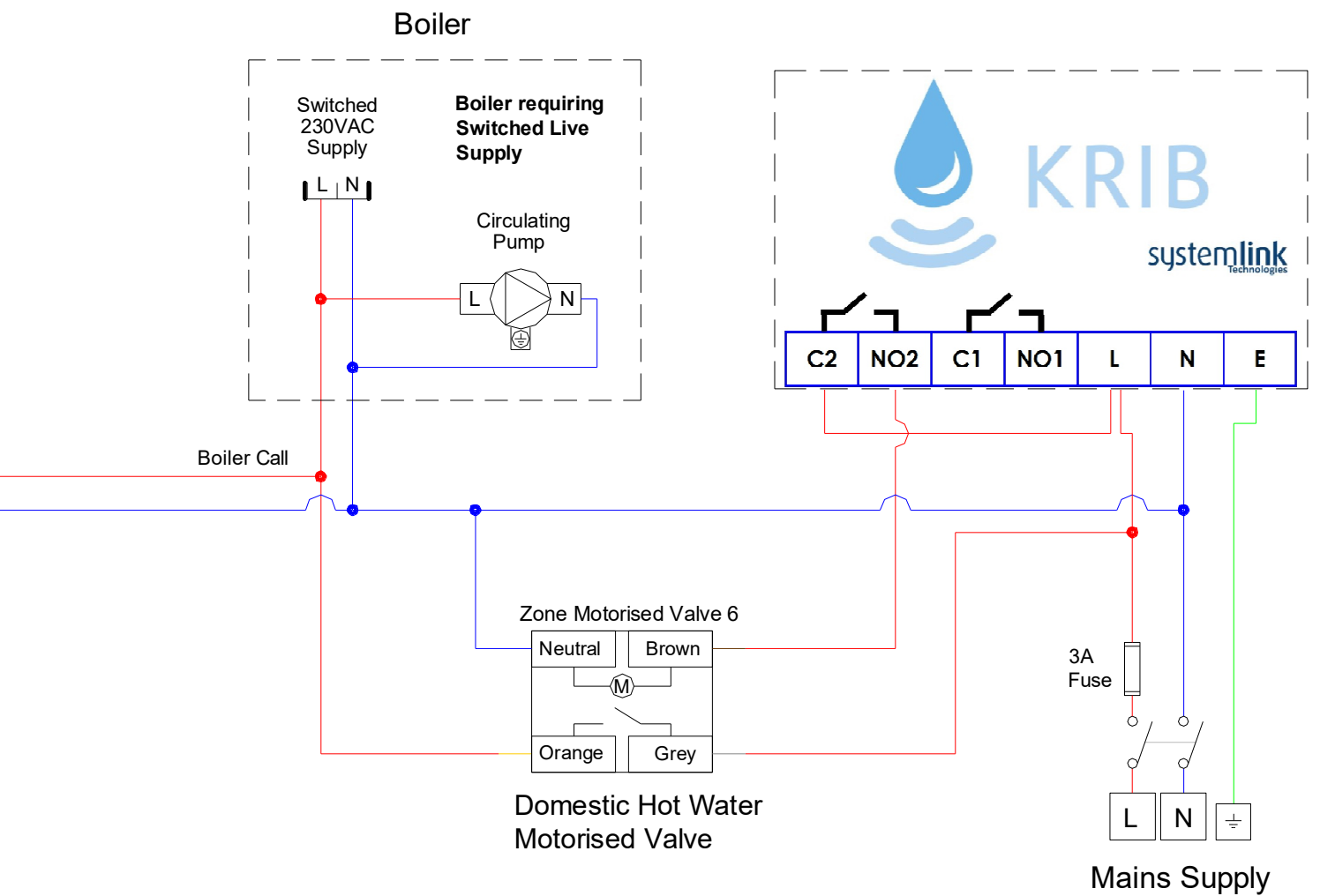

Schematic 7b. Electrical Wiring for KRIB system zoned with motorised valves (option 2) continued

The Gateway

The KRIB system uses the Gateway to communicate over the internet, which allows the system to be controlled by the smartphone App and to receive over-the-air updates.

Before powering up the Gateway, all wiring to the Touchscreen and the KRIB Control PCB should be completed first.

To install the Gateway a spare network port on a broadband router is required along with a standard 230V power socket. The internet connection on the Gateway should be connected to the spare network port on the router using the network cable provided.

Finally, fit the power supply cable end connector into the Gateway and then plug the power supply into the power socket.



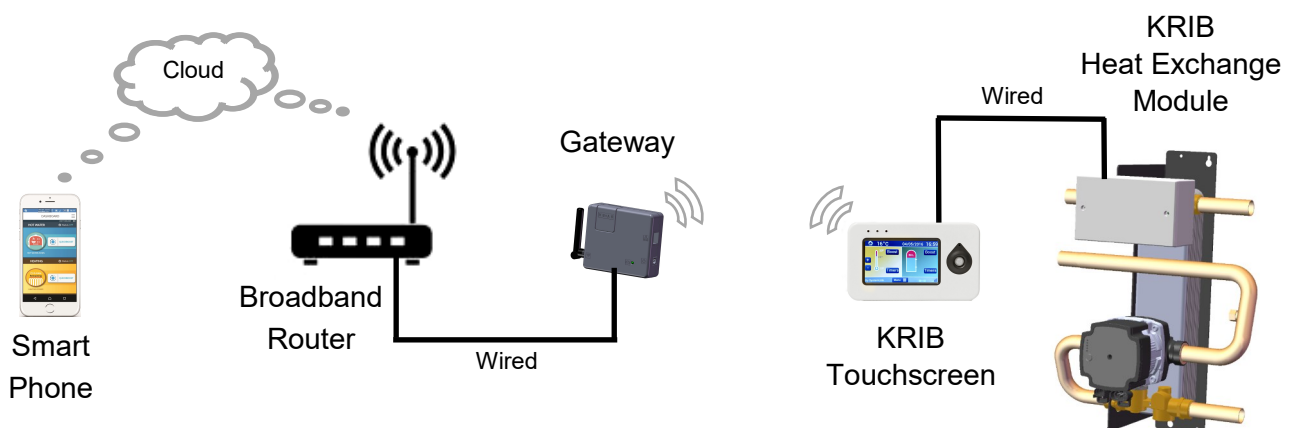

The Indicator LED indicates when power is connected. The Ethernet connection LED indicates when there is communication.

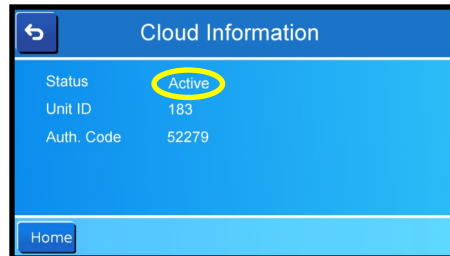

KRIB Electronics System Set-Up

1. Switch on power supply to the Gateway (ensure the Gateway is connected to the broadband router). From the main menu select Cloud.  If Status is **Active** skip to step 6, otherwise if Status is **Inactive** continue to step 2.



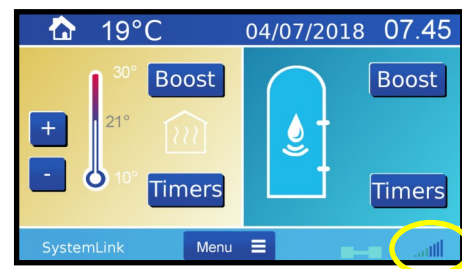
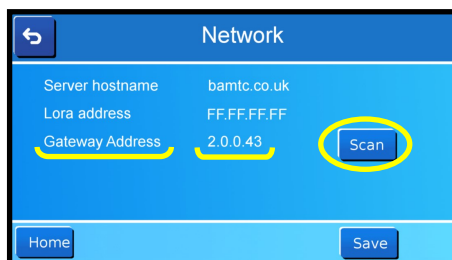

2. From the main menu **Menu**  enter the Installer Menu  on the Touchscreen. Enter pin code 1111.
3. Select Gateway  and press **Scan**.  This should populate the Gateway Address. Press **Save**  (The gauge at the bottom right of the Home Screen Dashboard should now indicate a wireless signal).





4. If the Gateway will not scan, disconnect and reconnect Gateway power and repeat the scan procedure and/or move the Gateway and Touchscreen closer together. Note that the Gateway can only be scanned for the first 30 seconds on each occasion after being powered on.
5. Return to the Installer Menu. Enter Cloud. Press **Activate** to connect the KRIB to the cloud. Status should change to **Active**.
6. At this point data from the Touchscreen will be sent to the cloud. This data contains information about the zones, settings and configurations as it is the first time it is being connected. Allow the unit approximately 15 minutes to transfer this data before trying to use the mobile app.

- Next install the KRIB App from the Play Store for an Android device or the App Store for an Apple device.
- Open the App and enter details as found in “Cloud” from the Main Menu on the Touchscreen. The App is now ready to use.

KRIB General System Set-Up

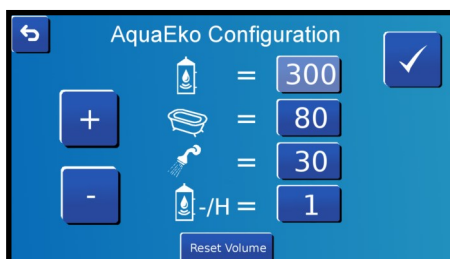
- From the main menu enter the Installer Menu  on the Touchscreen. Enter pin code 1111.
- Select AquaEko.  Set the volume of the cylinder, bath, shower and cylinder heat degradation in this screen. Set these up correctly before setting any timers. The heat degradation unit is litres/hour and the default value is set to 1. This is the number of litres of hot water which will be subtracted from the heated volume every hour to account for the heat loss of the cylinder, which will vary depending on the level of insulation of the cylinder. Note if volumes are changed, timer volumes will need to be adjusted separately.



- Enter the Installer Menu again.  Select Zones.  In this screen zone names can be set and also whether a zone is a heating zone or a standalone electrical switch e.g. lights or electric gates. A zone set to electrical switch will not switch on the boiler when active.

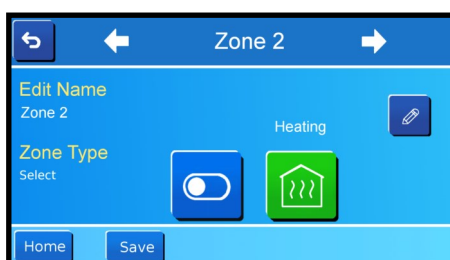

Troubleshooting

1. KRIB pump does not run.
 - * Flow from boiler not reaching sufficient temperature compared to DHW set-point. Raise boiler set-point or lower DHW set-point. Boiler flow temperature needs to be 3° above DHW set-point or the pump will not start. Temperatures can be confirmed in the Installer/Sensors screen.
 - Pump not in correct setting or air in circuit. Air can be purged at the fittings. Pump can be temporarily set to manual mode LED's 1,2,5 to aid air purge. See page 4 for instructions to adjust correct pump setting.
2. Boiler &/or KRIB pump switches on and off frequently during a heating period.
 - Insufficient Boiler Flow Rate.
 - See * above. If boiler set-point is not set high enough relative to the DHW set-point the boiler will keep shutting off on temperature and stable flowrate of DHW through the KRIB will not be achieved.
3. Timed KRIB water order failed.
 - Timed order will be cancelled if boiler does not reach sufficient temperature within the 30 min time-out period.
4. KRIB Timer water volume heated not what was expected.
 - Check Timer Water Volume. If the Cylinder, Bath, Shower volumes have been changed in the Touchscreen Installer/KRIB Screen, timer volumes will need to be updated.
5. Water volume on screen continuously reduces in amount.
 - This is due to the degradation of heat in the cylinder and is to be expected. The degradation value can be adjusted in the Installer KRIB screen to allow for more or less heat loss depending on whether a cylinder is badly or well insulated.
6. KRIB pump runs constantly.
 - Pump not in correct setting. See page 4.

Sensors Screen

The Menu/Installer/Sensors screen displays various sensor readings which can be useful in diagnosing problems. **Note Temperature Sensor #2 must be at least 3° above the Set-Point or the system will not run.**

- Flow Sensor #1 - Flow of heated water into cylinder.
- Flow Sensor #2 - Flow of hot water to taps.
- Temperature Sensor #1 - Temp of heated water into cylinder.
- Temperature Sensor #2 - Temp of water from Boiler.
- CV - Pump Speed.
- Set-Point - Hot Water Temperature setting

KRIB Internal Control PCB Connections Overview

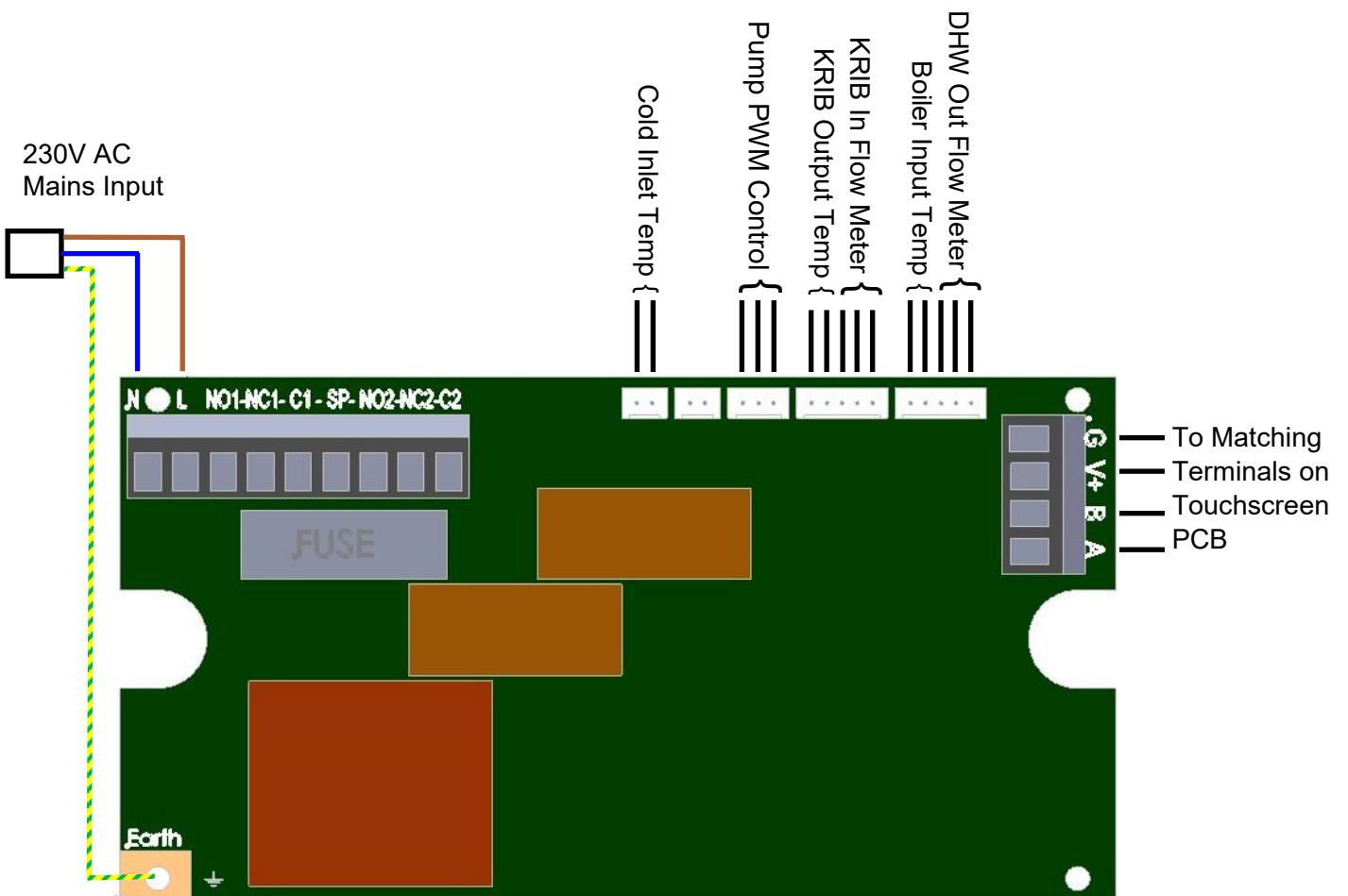
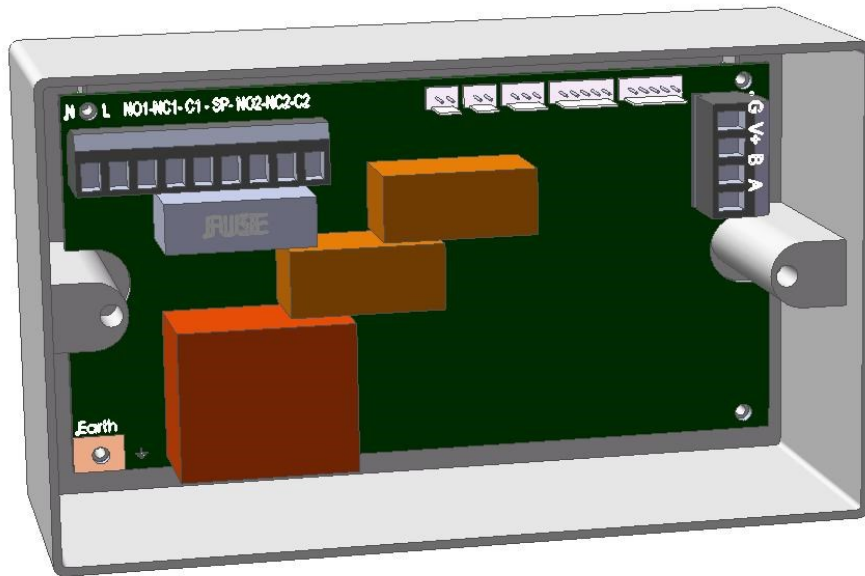

KRIB Internal Control PCB Low Voltage Connections

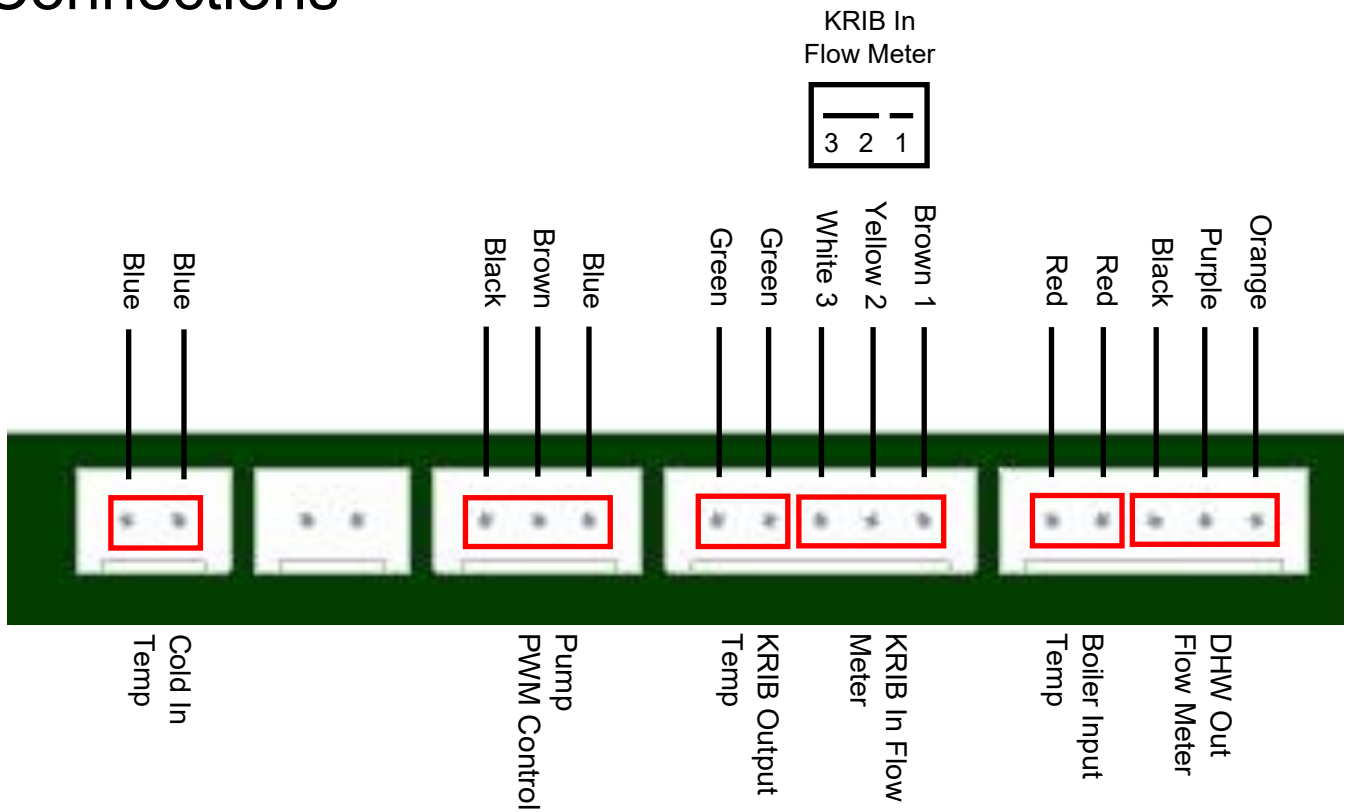

KRIB Internal Control PCB 230V AC Connections

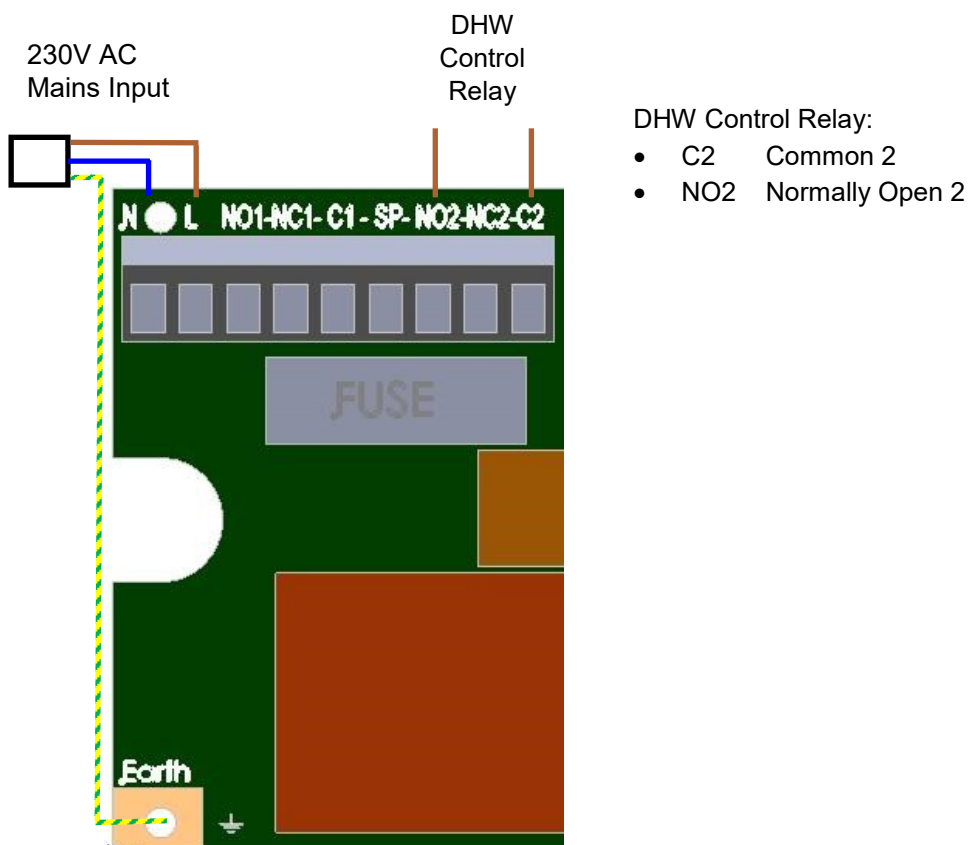

Dimensions:

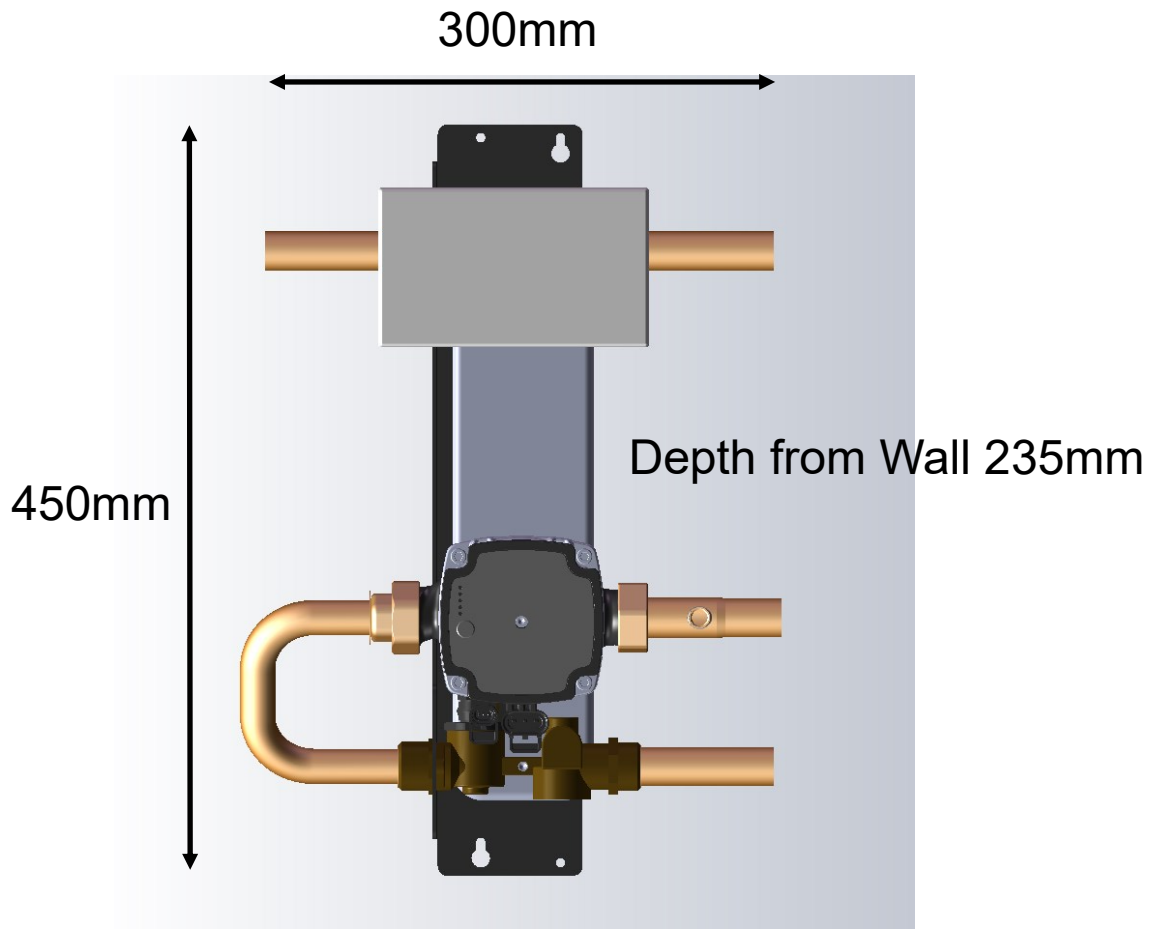

Specifications:

Connection Type: Metric 22mm or Imperial 3/4" Copper Pipe

Heat Exchanger Material: Stainless Steel

Maximum Working Pressure: Primary Side 3bar / Secondary Side 6bar

Maximum Working Temperature: Primary Side:85°C / Secondary Side:70°C

Fuse Ratings: KRIB PCB 5A / Touchscreen PCB 2X 3A. Anti-Surge.

Relay Ratings: KRIB PCB - Maximum 5A resistive switching capacity

Touchscreen - Maximum 2A resistive switching capacity

Contact Information: See <http://www.systemlink.ie/contact.html>



KRIB
Hot Water On Demand